

250G LC/300G LC

26 250–31 150-kg (57,800–68,674 lb.) Operating Weight



JOHN DEERE





Accelerate your profitability.

With powerful digging forces, swing torques, and lift capacities making the most of every gallon of fuel, the 250G LC and 300G LC Excavators will fast-track your bottom line. Rugged EPA Final Tier 4 (FT4)/EU Stage IV PowerTech™ diesel engines meet rigid emission regulations, enabling you to work, wherever there's work — without compromising power, reliability, or ease of operation. Customer-inspired refinements include comfortable, spacious cabs. And refined LCD monitors with simplified navigation that let an operator easily dial-in to a wealth of machine information and functionality. But that's only the beginning. To learn all there is to know about the G-Series Excavator lineup, make tracks to your John Deere dealer.



Specifications	250G LC	300G LC
Net Rated Power	140 kW (188 hp)	166 kW (223 hp)
Operating Weight	26 250 kg (57,800 lb.)	31 150 kg (68,674 lb.)
Maximum Digging Depth	7.61 m (25 ft. 0 in.)	7.87 m (25 ft. 10 in.)
Arm Digging Force	112.2–114 kN (25,224–25,628 lb.)	121–127 kN (27,202–28,551 lb.)
Bucket Digging Force	164–189 kN (36,869–42,489 lb.)	175–202 kN (39,342–45,411 lb.)



Got a lot on your plate? Dig in.

If you need to serve up more productivity, the 250G LC and 300G LC have insatiable appetites for work. Optimized hydraulics yield more muscle, so you can get in, get done, and get on to the next job. Even with their extra ability, these excavators don't compromise the smooth control and multifunction capability that have become the trademarks of John Deere excavators. And if you're hungry for even more productivity, add any of the many options and pile even more on your plate.

Choose from a variety of track widths, arm lengths, buckets, high-flow auxiliary hydraulic packages, and other options.

Powerwise™ III perfectly balances engine performance and hydraulic flow for predictable operation. Three productivity modes allow you to choose the digging style that fits the job. **High-productivity** delivers more power and faster hydraulic response to move more material. **Power** delivers a balance of power, speed, and fuel economy for normal operation. **Economy** limits top speed and helps save fuel.

Machine Information Center (MIC) captures and stores vital machine performance and utilization data to help improve productivity, uptime, and profit.

New 300G LC delivers 19-percent more horsepower and 17-percent more swing torque than the 290G LC it replaces, for even more productivity. Larger pumps similar to those on the 350G LC boost hydraulic horsepower.



1. For work that requires extra finesse, the G-Series' short-throw low-effort controls, unmatched metering, and smooth multifunction operation give the precision you need.

2. Generous flow, arm force, and swing torque help speed cycles. So you can do your best to stay on schedule or ahead of the weather.

3. When the digging gets tough, simply press the power-boost button on the right-hand control and muscle through.



The image shows the interior of a John Deere G-Series excavator cab. The operator's seat is a high-back, fabric-covered seat with armrests. In front of the seat is a control panel with a large rotary dial on the left side, which houses a small LCD monitor. To the right of the dial are several joysticks and buttons. A red-handled tool is visible in the lower right foreground. The background shows the yellow exterior of the excavator and various warning labels on the cab's structure.

Operating ease takes a turn for the better.

G-Series Excavators make it easy for your operators to “dial things up.” The refined monitor employs a rotary control that makes it quick and easy to tap into an abundance of performance and convenience functions and features. Operators will also appreciate the comfortable fabric-covered high-back seat and generous legroom in the spacious, well-appointed cab. As always, unsurpassed all-round visibility, low-effort joysticks, a highly efficient HVAC system, and numerous other amenities provide everything your operators need to do their best work.



With generous legroom, the spacious cab delivers daylong convenience and comfort. Silicone-filled mounts effectively isolate operators from noise and vibration.

We've got your back with a sculpted mechanical-suspension high-back seat. Seat has 318 mm (12½ in.) of travel, sliding together or independent of the joystick console. For even more support and comfort, opt for the air-suspension heated seat.

No shortage of storage in here. There's a place for a cooler, cup holders, and even a hot/cold box that keeps beverages at just the right temperature.

Optional cab and right-side boom lights provide extra illumination to extend your workday beyond normal daylight hours. Engine-compartment light makes it easy to see daily service points in low-light conditions.

New hood design ensures optimal visibility to the sides and rear, even with the increased under-the-hood space requirements of EPA Final Tier 4 (FT4)/EU Stage IV components.

Programmable thumb-attachment mode allows you to set oil flow within the monitor.

1. Multi-language LCD monitor and rotary dial provide intuitive access to a wealth of information and functions. Just turn and tap to select work mode, access operating info, check maintenance intervals, source diagnostic codes, adjust cab temperature, and tune the radio. Plus much more.
2. Wide expanse of front and side glass, narrow front cab posts, large overhead mirrors provide virtually unobstructed all-around visibility. If you need to see more, choose the optional camera that displays the action behind on the monitor.
3. Ergonomically correct short-throw pilot levers provide smooth, precise fingertip control with less movement or effort. Push buttons in the right lever allow predictable control of auxiliary hydraulic flow for operating attachments. Optional sliding switch provides proportional speed control, giving you full command at your fingertips.
4. Automatic, high-velocity bi-level climate-control system with automotive-style adjustable louvers helps keep the glass clear and the cab comfortable.



Nothing runs like a Deere, because nothing is built like one.

Got places to go, people to see, and schedules to keep? Add these go-getters to your lineup. Built to deliver unsurpassed uptime, these dependable workers employ many of the same job-proven digging structures and hydraulic, electrical, and undercarriage components as their highly regarded predecessors. You'll also continue to profit from durability-enhancing "extras" such as tungsten-carbide-coated wear surfaces, welded-boom bulkheads, wet-sleeve engine liners, and extended service intervals. When you know how they're built, you'll run a Deere.

A John Deere exclusive, three welded bulkheads within the boom resist torsional stress for unsurpassed durability. Booms, arms, and mainframes are so tough, they're warranted for three years or 10,000 hours.

Graphite-iron wet-sleeve cylinder liners, mono-steel pistons, and large-diameter connecting rods ensure long-term engine durability.

Cool-on-demand hydraulic-driven fan provides optimum cooling while reducing noise and conserving fuel.

Optional grade-reference system includes sensor mounts to help speed installation, eliminating the need to grind, weld, and repaint. Our "open-architecture" design allows you to employ your favorite brand of grade-control system to help maximize productivity and uptime while lowering daily operating costs.

To meet stringent EPA Final Tier 4 (FT4)/EU Stage IV standards, we built on our Interim Tier 4 (IT4)/Stage IIIB solution to deliver the best combination of performance, efficiency, and reliability without sacrificing power or torque. Our field-proven technology is simple, fluid efficient, fully integrated, and fully supported. It employs field-proven cooled exhaust gas recirculation (EGR), easy-to-maintain high-uptime exhaust filters, and selective catalytic reduction (SCR).

Oil-impregnated bushings enhance durability and extend grease intervals to 500 hours for the arm-and-boom joint and 100 hours for the bucket joint.

Tungsten-carbide coating creates an extremely wear-resistant surface to protect the all-important bucket-to-arm joint.



1. Reinforced D-channel side frames with recessed doors provide maximum cab and component protection.





2. Thick-plate single-sheet mainframe, box-section track frames, and industry-exclusive double-seal swing bearing deliver rock-solid durability.

3. With large idlers, rollers, and strutted links, the sealed and lubricated undercarriage delivers long and reliable performance.

4. Optional hydraulic reversing fan feature allows the operator to automatically back blow the cooling cores to improve uptime.



You'll become a big fan of the G-Series' low maintenance.

Swing open the side panels and you'll discover many of the numerous ways these excavators can minimize maintenance, increase uptime, and reduce daily operating costs. Hydraulically driven fan runs only as fast or often as needed, reducing fuel consumption and wear-causing debris flow through the cooler cores. Grouped service points make quick work of the daily routine. Easy-to-check sight gauges and fluid reservoirs. Quick-change remote-mounted filters. Convenient fluid-sample ports and advanced self-diagnostics — with time- and money-saving advantages such as these, and a dealer-customized Ultimate Uptime package to help optimize your operation, there's more to like.

1. LCD monitor tracks scheduled maintenance intervals and issues reminders, including DPF servicing. Should a problem arise, it provides diagnostic information to help decrease downtime.
2. Easily accessible fluid-sample ports and in-cab diagnostic displays help speed preventative maintenance and defeat downtime.
3. Fresh-air cab filter is quickly serviced from outside the cab. Where it's more likely to get done.
4. Vertical spin-on fuel and engine oil filters are positioned in the right rear compartment for simplified ground-level servicing.
5. Centralized lube banks place difficult-to-lube zerks within easy reach. They make greasing less messy and time consuming, too.
6. Diesel exhaust fluid (DEF) can be conveniently filled when refueling due to its large and accessible tank. DEF overflow routes excess outside the machine to avoid paint damage.

Ash-service intervals for the diesel particulate filter (DPF) are condition based, with the machine notifying the operator before service is required. Typically, ash service is not necessary until the first engine overhaul depending on machine application and maintenance practices. FT4 components are warranted for 10,000 hours.



1	Engine Oil Filter
Previous Maintenance	
2013/06/06	0.0h
Remains	498.8h
Maintenance Interval	500.0h



Large fuel tanks and 500- and 5,000-hour engine and hydraulic oil-service intervals decrease downtime for routine maintenance. Fluid-level sight gauges are conveniently located and can be checked at a glance.

Larger hood enables greater access to engine components for easy daily service and the ability to inspect the engine, drive belt, and coolant and oil levels from one location.

Upper-structure handrails provide three points of contact when accessing the engine compartment. Slip-resistant surfaces help improve stability.

Auto-idle automatically reduces engine speed when hydraulics aren't in use. Auto-shutdown further preserves precious fuel.

Optional reversing fan back-blows cooler cores to reduce debris buildup. It's a welcome addition that helps increase uptime.

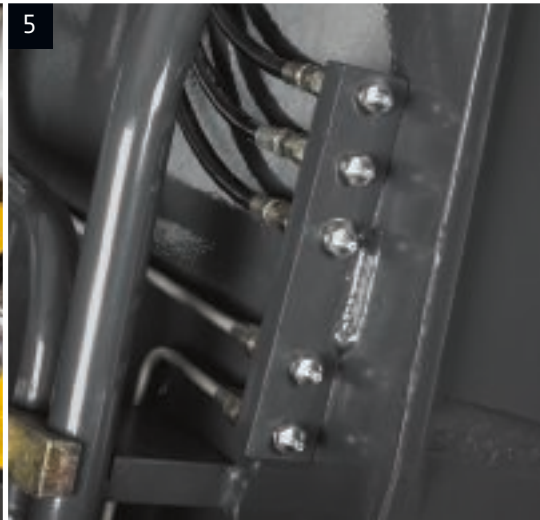

250G LC

Engine	250G LC		
	Base engine for use in U.S., U.S. Territories, and Canada	Optional engine for use outside the U.S. and U.S. Territories	
Manufacturer and Model	John Deere PowerTech™ PVS 6.8 L	John Deere PowerTech™ Plus 6.8 L	
Non-Road Emission Standard	EPA Final Tier 4/EU Stage IV	EPA Tier 3/EU Stage IIIA	
Net Rated Power (ISO 9249)	140 kW (188 hp) at 2,100 rpm	132 kW (177 hp) at 2,000 rpm	
Cylinders	6	6	
Displacement	6.8 L (415 cu. in.)	6.8 L (415 cu. in.)	
Off-Level Capacity	70% (35 deg.)	70% (35 deg.)	
Aspiration	Turbocharged, air-to-air charge-air cooler	Turbocharged, air-to-air charge-air cooler	
Cooling			
Cool-on-demand hydraulic-driven, suction-type fan with remote-mounted drive			
Powertrain			
2-speed propel with automatic shift			
Maximum Travel Speed			
Low	3.3 km/h (2.1 mph)		
High	5.5 km/h (3.4 mph)		
Drawbar Pull	21 900 kg (48,300 lb.)		
Hydraulics			
Open center, load sensing			
Main Pumps			
Maximum Rated Flow	224 L/m (59.2 gpm) x 2		
System Operating Pressure			
Circuits			
Implement	34 300 kPa (4,975 psi)		
Travel	35 000 kPa (5,076 psi)		
Swing	32 400 kPa (4,830 psi)		
Power Boost	38 000 kPa (5,511 psi)		
Controls			
Pilot levers, short stroke, low-effort hydraulic pilot controls with shutoff lever			
Cylinders			
	<i>Bore</i>	<i>Rod Diameter</i>	<i>Stroke</i>
Boom (2)	125 mm (4.9 in.)	90 mm (3.5 in.)	1390 mm (54.7 in.)
Arm (1)	140 mm (5.5 in.)	100 mm (3.9 in.)	1610 mm (63.4 in.)
Bucket (1)	130 mm (5.1 in.)	90 mm (3.5 in.)	1075 mm (42.3 in.)
Electrical			
Number of Batteries (12 volt)	2		
Battery Capacity	1,400 CCA		
Alternator Rating	100 amp		
Work Lights	2 halogen (one mounted on boom, one on frame)		
Undercarriage			
Rollers (each side)			
Carrier	2		
Track	9		
Shoes, Triple Semi-Grousers (each side)	51		
Track			
Adjustment	Hydraulic		
Guides	2 per side		
Chain	Sealed and lubricated		
Ground Pressure			
Triple Semi-Grouser Shoes			
600 mm (23 in.)	50.8 kPa (7.36 psi)		
700 mm (28 in.)	44.6 kPa (6.47 psi)		
800 mm (32 in.)	39.1 kPa (5.66 psi)		



Swing Mechanism	250G LC
Speed	13.5 rpm
Torque	77 500 Nm (57,150 lb.-ft.)

Serviceability

Refill Capacities	
Fuel Tank	500 L (132 gal.)
Diesel Exhaust Fluid (DEF) Tank	35 L (9.3 gal.)
Cooling System	23 L (6 gal.)
Engine Oil with Filter	19.5 L (5.2 gal.)
Hydraulic Tank	147.6 L (39 gal.)
Hydraulic System	240 L (63 gal.)
Swing Drive	7 L (7.5 qt.)
Gearbox	
Propel (each)	6.2 L (6.5 qt.)
Pump Drive	1.1 L (1.2 qt.)

Operating Weights

With full fuel tank; 79-kg (175 lb.) operator; 1.06-m³ (1.38 cu. yd.), 1219-mm (48 in.), 1107-kg (2,440 lb.) bucket; 3.61-m (11 ft. 10 in.) arm; 5112-kg (11,270 lb.) counterweight; and 800-mm (32 in.) triple semi-grouser shoes

Operating Weight 26 250 kg (57,800 lb.)

Component Weights

Undercarriage with Triple Semi-Grouser Shoes	
600 mm (24 in.)	8077 kg (17,807 lb.)
700 mm (28 in.)	8467 kg (18,667 lb.)
800 mm (32 in.)	8752 kg (19,294 lb.)
One-Piece Boom (with arm cylinder)	2210 kg (4,872 lb.)
Arm with Bucket Cylinder and Linkage	
2.50 m (8 ft. 2 in.)	1225 kg (2,701 lb.)
2.96 m (9 ft. 9 in.)	1296 kg (2,858 lb.)
3.61 m (11 ft. 10 in.)	1396 kg (3,078 lb.)
Boom-Lift Cylinders (2), Total Weight	434 kg (958 lb.)

Operating Dimensions

Arm Length	<i>2.50 m (8 ft. 2 in.)</i>	<i>2.96 m (9 ft. 9 in.)</i>	<i>3.61 m (11 ft. 10 in.)</i>
Arm Digging Force			
SAE	154.0 kN (34,621 lb.)	129.1 kN (29,023 lb.)	112.2 kN (25,224 lb.)
ISO	158.0 kN (35,520 lb.)	131.0 kN (29,450 lb.)	114.0 kN (25,628 lb.)
Bucket Digging Force			
SAE	164.0 kN (36,869 lb.)	164.0 kN (36,869 lb.)	164.0 kN (36,869 lb.)
ISO	189.0 kN (42,489 lb.)	189.0 kN (42,489 lb.)	189.0 kN (42,489 lb.)
A Maximum Reach	9.88 m (32 ft. 5 in.)	10.29 m (33 ft. 9 in.)	10.91 m (35 ft. 10 in.)
A' Maximum Reach at Ground Level	9.69 m (31 ft. 9 in.)	10.11 m (33 ft. 2 in.)	10.75 m (35 ft. 3 in.)
B Maximum Digging Depth	6.50 m (21 ft. 4 in.)	6.96 m (22 ft. 10 in.)	7.61 m (25 ft. 0 in.)
B' Maximum Digging Depth at 2.44-m (8 ft. 0 in.) Flat Bottom	6.26 m (20 ft. 6 in.)	6.75 m (22 ft. 2 in.)	7.44 m (24 ft. 5 in.)
C Maximum Cutting Height	9.95 m (32 ft. 8 in.)	10.16 m (33 ft. 4 in.)	10.56 m (34 ft. 8 in.)
D Maximum Dumping Height	6.99 m (22 ft. 11 in.)	7.20 m (23 ft. 7 in.)	7.58 m (24 ft. 10 in.)
E Minimum Swing Radius	3.48 m (11 ft. 5 in.)	3.44 m (11 ft. 3 in.)	3.43 m (11 ft. 3 in.)
F Maximum Vertical Wall	5.58 m (18 ft. 4 in.)	6.03 m (19 ft. 9 in.)	6.74 m (22 ft. 1 in.)

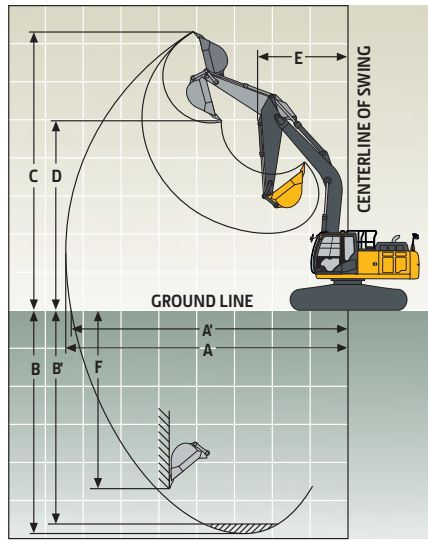

Machine Dimensions		250G LC		
Arm Length		2.50 m (8 ft. 2 in.)	2.96 m (9 ft. 9 in.)	3.61 m (11 ft. 10 in.)
A Overall Length		10.47 m (34 ft. 4 in.)	10.35 m (33 ft. 11 in.)	10.41 m (34 ft. 2 in.)
B Overall Height		3.37 m (11 ft. 1 in.)	3.07 m (10 ft. 1 in.)	3.14 m (10 ft. 4 in.)
C Tail-Swing Radius		3.14 m (10 ft. 4 in.)		
D Distance Between Idler/Sprocket Centerline		3.84 m (12 ft. 7 in.)		
E Undercarriage Length		4.64 m (15 ft. 3 in.)		
F Counterweight Clearance		1.09 m (3 ft. 7 in.)		
G Upperstructure Width		2.89 m (9 ft. 6 in.)		
H Cab Height		3.01 m (9 ft. 11 in.)		
I Track Width with Triple Semi-Grouser Shoes		600 mm (24 in.) / 700 mm (28 in.) / 800 mm (32 in.)		
J Gauge Width		2.59 m (8 ft. 6 in.)		
K Ground Clearance		0.46 m (18 in.)		
L Overall Width with Triple Semi-Grouser Shoes				
600 mm (24 in.)		3.19 m (10 ft. 6 in.)		
700 mm (28 in.)		3.29 m (10 ft. 9 in.)		
800 mm (32 in.)		3.39 m (11 ft. 1 in.)		

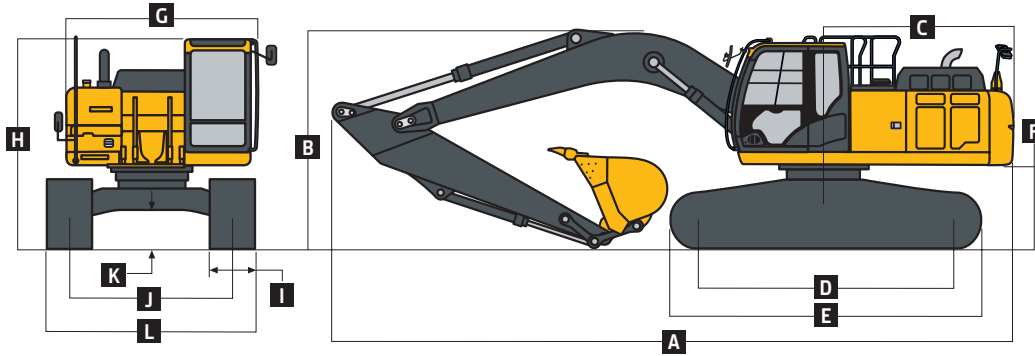

Lift Capacities

Boldface type indicates hydraulically limited capacity; lightface type indicates stability-limited capacities, in kg (lb.). Ratings at bucket lift hook; machine equipped with 851-kg (1,876 lb.) bucket; standard gauge; and situated on firm, uniform supporting surface. Total load includes weight of cables, hook, etc. Figures do not exceed 87 percent of hydraulic capacities or 75 percent of weight needed to tip machine. All lift capacities are based on ISO 10567.

LOAD POINT HEIGHT	HORIZONTAL DISTANCE FROM CENTERLINE OF ROTATION													
	1.5 m (5 ft.)		3.0 m (10 ft.)		4.5 m (15 ft.)		6.0 m (20 ft.)		7.5 m (25 ft.)		9.0 m (30 ft.)			
	Over Front	Over Side	Over Front	Over Side	Over Front	Over Side	Over Front	Over Side	Over Front	Over Side	Over Front	Over Side		
<i>With 2.96-m (9 ft. 9 in.) arm and 800-mm (32 in.) shoes</i>														
6.0 m (20 ft.)							5040	5040	4190	4190				
							(11,040)	(11,040)						
4.5 m (15 ft.)					6990	6990	5830	5830	5280	4230				
					(15,020)	(15,020)	(12,640)	(12,640)	(11,550)	(9,070)				
3.0 m (10 ft.)					9370	9360	6930	5910	5810	4070				
					(20,110)	(20,110)	(14,990)	(12,720)	(12,630)	(8,730)				
1.5 m (5 ft.)					11 410	8690	8010	5580	6220	3900				
					(24,580)	(18,720)	(17,320)	(12,010)	(13,360)	(8,370)				
Ground Line					12 370	8370	8730	5360	6080	3770				
					(26,750)	(17,990)	(18,740)	(11,520)	(13,070)	(8,110)				
-1.5 m (-5 ft.)			8640	8640	12 380	8290	8620	5260	6030	3720				
			(19,680)	(19,680)	(26,810)	(17,810)	(18,510)	(11,320)	(12,960)	(8,010)				
-3.0 m (-10 ft.)	10 140	10 140	14 820	14 820	11 560	8370	8460	5300						
	(22,820)	(22,820)	(33,800)	(33,800)	(25,000)	(18,000)	(18,230)	(11,400)						
-4.5 m (-15 ft.)			13 500	13 500	9590	8630								
			(28,980)	(28,980)	(20,500)	(18,570)								
<i>With 3.61-m (11 ft. 10 in.) arm and 700-mm (28 in.) shoes</i>														
6.0 m (20 ft.)							4290	4290	3990	3990				
							(9,400)	(9,400)	(8,480)	(8,480)				
4.5 m (15 ft.)							5120	5120	4740	4250				
							(11,100)	(11,100)	(10,300)	(9,120)				
3.0 m (10 ft.)					8210	8210	6280	5960	5340	4070	3710	2890		
					(28,820)	(28,820)	(17,640)	(17,640)	(13,580)	(12,820)	(11,610)	(8,730)	(7,190)	(6,170)
1.5 m (5 ft.)					10 530	8780	7480	5580	6000	3870	4350	2790		
					(22,680)	(18,910)	(16,180)	(12,020)	(13,020)	(8,310)	(8,490)	(5,980)		
Ground Line			4660	4660	11 950	8310	8400	5300	6000	3710	4260	2720		
			(10,740)	(10,740)	(25,830)	(17,870)	(18,180)	(11,410)	(12,660)	(7,970)	(7,770)	(5,830)		
-1.5 m (-5 ft.)	4520	4520	7870	7870	12 390	8130	8480	5150	5900	3620				
	(10,150)	(10,150)	(17,910)	(17,910)	(26,820)	(17,470)	(17,890)	(11,080)	(12,450)	(7,780)				
-3.0 m (-10 ft.)	8200	8200	12 340	12 340	11 980	8140	8450	5130	5900	3620				
	(18,440)	(18,440)	(28,100)	(28,100)	(25,910)	(17,490)	(17,840)	(11,040)	(12,480)	(7,810)				
-4.5 m (-15 ft.)	12 810	12 810	15 370	15 370	10 590	8320	7640	5250						
	(28,980)	(28,980)	(33,080)	(33,080)	(22,760)	(17,890)	(16,280)	(11,330)						
-6.0 m (-20 ft.)					7300	7300								

Lift Capacities (continued) 250G LC

Boldface type indicates hydraulically limited capacity; lightface type indicates stability-limited capacities, in kg (lb.). Ratings at bucket lift hook; machine equipped with 851-kg (1,876 lb.) bucket; standard gauge; and situated on firm, uniform supporting surface. Total load includes weight of cables, hook, etc. Figures do not exceed 87 percent of hydraulic capacities or 75 percent of weight needed to tip machine. All lift capacities are based on ISO 10567.

HORIZONTAL DISTANCE FROM CENTERLINE OF ROTATION

LOAD POINT HEIGHT	1.5 m (5 ft.)		3.0 m (10 ft.)		4.5 m (15 ft.)		6.0 m (20 ft.)		7.5 m (25 ft.)		9.0 m (30 ft.)			
	Over Front	Over Side	Over Front	Over Side	Over Front	Over Side	Over Front	Over Side	Over Front	Over Side	Over Front	Over Side		
<i>With 3.61-m (11 ft. 10 in.) arm and 800-mm (32 in.) shoes</i>														
6.0 m (20 ft.)								4290	4290	3990	3990			
								(9,400)	(9,400)	(8,480)	(8,480)			
4.5 m (15 ft.)								5120	5120	4740	4300			
								(11,100)	(11,100)	(10,300)	(9,230)			
3.0 m (10 ft.)							8210	8210	6280	6020	5340	4120		
			(28,820)	(28,820)	(17,640)	(17,640)	(13,580)	(12,960)	(11,610)	(8,840)	(7,190)	(6,250)		
1.5 m (5 ft.)							10 530	8870	7480	5650	6000	3920		
							(22,680)	(19,110)	(16,180)	(12,150)	(13,020)	(8,420)	(8,490)	(6,060)
Ground Line			4660	4660	11 950	8410	8400	5370	6070	5370	3760	4260	2760	
			(10,740)	(10,740)	(25,830)	(18,080)	(18,180)	(11,540)	(13,050)	(8,070)	(7,770)	(5,910)		
-1.5 m (-5 ft.)	4520	4520	7870	7870	12 390	8220	8580	5220	5970	3670				
	(10,150)	(10,150)	(17,910)	(17,910)	(26,820)	(17,670)	(18,420)	(11,220)	(12,840)	(7,880)				
-3.0 m (-10 ft.)	8200	8200	12 340	12 340	11 980	8240	8550	5200	5980	3670				
	(18,440)	(18,440)	(28,100)	(28,100)	(25,910)	(17,700)	(18,370)	(11,180)	(12,870)	(7,910)				
-4.5 m (-15 ft.)	12 810	12 810	15 370	15 370	10 590	8410	7640	5320						
	(28,980)	(28,980)	(33,080)	(33,080)	(22,760)	(18,090)	(16,280)	(11,470)						
-6.0 m (-20 ft.)					7300	7300								

Buckets

A full line of buckets is offered to meet a wide variety of applications. Digging forces are with power boost. Buckets are equipped with John Deere TK-Series Bucket Teeth standard. Replaceable cutting edges and a variety of teeth are available through John Deere Parts. Optional side cutters add 150 mm (6 in.) to bucket widths. Capacities are SAE heaped ratings.

Type Bucket	Bucket Width		Bucket Capacity		Bucket Weight		Bucket Dig Force		Arm Dig Force, 2.50 m (8 ft. 2 in.)		Arm Dig Force, 2.96 m (9 ft. 9 in.)		Arm Dig Force, 3.61 m (11 ft. 10 in.)		Bucket Tip Radius		Number of Teeth
	mm	in.	m ³	cu. yd.	kg	lb.	kN	lb.	kN	lb.	kN	lb.	kN	lb.	mm	in.	
Heavy Duty	1065	42	1.06	1.4	997	2,197	176.0	39,558	154.0	34,621	129.1	29,021	112.2	25,220	1435	56.5	5
	1220	48	1.22	1.6	1071	2,361	176.0	39,558	154.0	34,621	129.1	29,021	112.2	25,220	1435	56.5	6
	1372	54	1.39	1.8	1138	2,509	176.0	39,558	154.0	34,621	129.1	29,021	112.2	25,220	1435	56.5	6
Heavy Duty High Capacity	610	24	0.70	0.9	801	1,767	167.4	37,636	148.2	33,317	124.7	28,044	108.9	24,477	1588	62.5	3
	760	30	0.92	1.2	913	2,012	167.4	37,636	148.2	33,317	124.7	28,044	108.9	24,477	1588	62.5	4
	914	36	1.13	1.5	968	2,135	167.4	37,636	148.2	33,317	124.7	28,044	108.9	24,477	1588	62.5	4
	1065	42	1.34	1.7	1035	2,281	167.4	37,636	148.2	33,317	124.7	28,044	108.9	24,477	1588	62.5	5
	1220	48	1.55	2.0	1137	2,507	167.4	37,636	148.2	33,317	124.7	28,044	108.9	24,477	1588	62.5	6

Bucket Selection Guide*

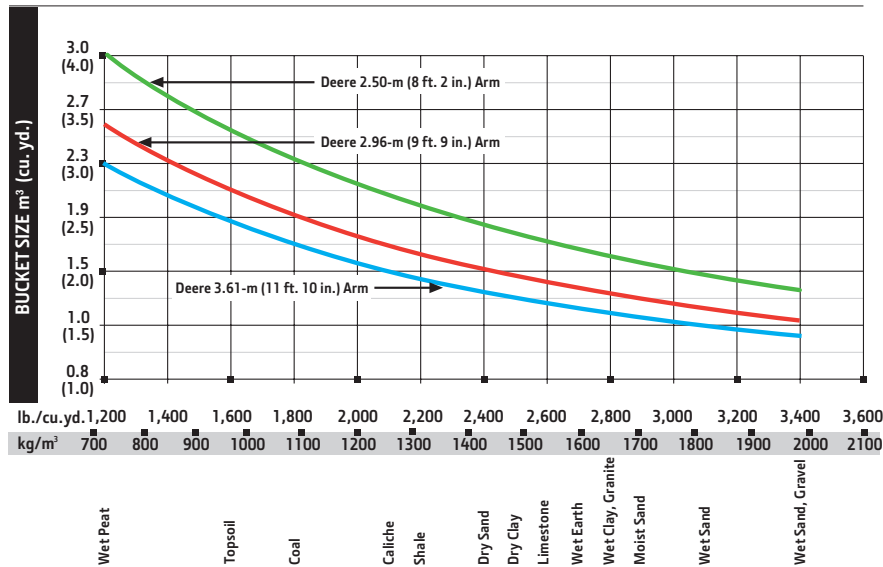

*Contact your John Deere dealer for optimum bucket and attachment selections. These recommendations are for general conditions and average use. Does not include optional equipment such as thumbs or couplers. Larger buckets may be possible when using light materials, for flat and level operations, less compacted materials, and volume loading applications such as mass-excavation applications in ideal conditions. Smaller buckets are recommended for adverse conditions such as off-level applications, rocks, and uneven surfaces. Bucket capacity indicated is SAE heaped.

300G LC

Engine	300G LC		
	Base engine for use in U.S., U.S. Territories, and Canada		
Manufacturer and Model	John Deere PowerTech™ PSS 6.8L, 6068HT107		
Non-Road Emission Standard	EPA Final Tier 4/EU Stage IV		
Net Rated Power (ISO 9249)	166 kW (223 hp) at 1,900 rpm		
Cylinders	6		
Displacement	6.8 L (415 cu. in.)		
Off-Level Capacity	70% (35 deg.)		
Aspiration	Series turbocharged, air-to-air charge-air cooler		
Cooling			
	Cool-on-demand hydraulic-driven, suction-type fan with remote-mounted drive		
Powertrain			
	2-speed propel with automatic shift		
Maximum Travel Speed			
Low	3.1 km/h (1.9 mph)		
High	5.2 km/h (3.2 mph)		
Drawbar Pull	25 085 kg (55,303 lb.)		
Hydraulics			
	Open center, load sensing		
Main Pumps	2 variable-displacement pumps		
Maximum Rated Flow	236 L/m (62.3 gpm) x 2		
System Operating Pressure			
Circuits			
Implement	34 300 kPa (4,975 psi)		
Travel	35 500 kPa (5,149 psi)		
Swing	33 300 kPa (4,830 psi)		
Power Boost	38 000 kPa (5,511 psi)		
Controls	Pilot levers, short stroke, low-effort hydraulic pilot controls with shutoff lever		
Cylinders			
	<i>Bore</i>	<i>Rod Diameter</i>	<i>Stroke</i>
Boom (2)	135 mm (5.3 in.)	95 mm (3.7 in.)	1422 mm (56.0 in.)
Arm (1)	150 mm (5.9 in.)	105 mm (4.1 in.)	1659 mm (65.3 in.)
Bucket (1)	135 mm (5.3 in.)	90 mm (3.5 in.)	1070 mm (42.1 in.)
Electrical			
Number of Batteries (12 volt)	2		
Battery Capacity	1,000 CCA		
Alternator Rating	100 amp		
Work Lights	2 halogen (one mounted on left-hand side of boom, one on frame)		
Undercarriage			
Rollers (each side)			
Carrier	2		
Track	8		
Shoes, Triple Semi-Grousers (each side)	48		
Track			
Adjustment	Hydraulic		
Guides	2 per side		
Chain	Sealed and lubricated		
Ground Pressure			
Triple Semi-Grouser Shoes			
700 mm (28 in.)	50.0 kPa (7.26 psi)		
800 mm (32 in.)	43.8 kPa (6.35 psi)		



Swing Mechanism	300G LC
Speed	10.3 rpm
Torque	90 500 Nm (66,749 lb.-ft.)

Serviceability

Refill Capacities	
Fuel Tank	514 L (136 gal.)
Diesel Exhaust Fluid (DEF) Tank	35 L (9.2 gal.)
Cooling System	36 L (9.5 gal.)
Engine Oil with Filter	20.5 L (5 gal.)
Hydraulic Tank	156 L (41 gal.)
Hydraulic System	290 L (77 gal.)
Swing Drive	12 L (12.7 qt.)
Gearbox	
Propel (each)	9.2 L (9.7 qt.)
Pump Drive	1.1 L (1.2 qt.)

Operating Weights

With full fuel tank; 79-kg (175 lb.) operator; 1.44-m³ (1.88 cu. yd.), 1067-mm (42 in.), 1158-kg (2,553 lb.) bucket; 3.76-m (12 ft. 4 in.) arm; 5600-kg (12,346 lb.) counterweight; and 800-mm (32 in.) triple semi-grouser shoes

Operating Weight	31 150 kg (68,674 lb.)
------------------	------------------------

Component Weights

Undercarriage with Triple Semi-Grouser Shoes	
700 mm (28 in.)	11 478 kg (25,305 lb.)
800 mm (32 in.)	11 881 kg (26,193 lb.)
One-Piece Boom (with arm cylinder)	
2322 kg (5,119 lb.)	
Arm with Bucket Cylinder and Linkage	
3.11 m (10 ft. 2 in.)	1288 kg (2,840 lb.)
3.76 m (12 ft. 4 in.)	1377 kg (3,036 lb.)
Boom-Lift Cylinders (2), Total Weight	
490 kg (1,080 lb.)	

Operating Dimensions

Arm Length	3.11 m (10 ft. 2 in.)	3.76 m (12 ft. 4 in.)
Arm Digging Force		
SAE	138 kN (31,024 lb.)	121 kN (27,202 lb.)
ISO	144 kN (32,372 lb.)	127 kN (28,551 lb.)
Bucket Digging Force		
SAE	175 kN (39,342 lb.)	175 kN (39,342 lb.)
ISO	202 kN (45,411 lb.)	202 kN (45,411 lb.)
A	Maximum Reach	10.71 m (35 ft. 2 in.)
A¹	Maximum Reach at Ground Level	10.52 m (34 ft. 6 in.)
B	Maximum Digging Depth	7.22 m (23 ft. 8 in.)
B¹	Maximum Digging Depth at 2.44-m (8 ft. 0 in.) Flat Bottom	7.04 m (23 ft. 1 in.)
C	Maximum Cutting Height	10.27 m (33 ft. 8 in.)
D	Maximum Dumping Height	7.33 m (24 ft. 1 in.)
E	Minimum Swing Radius	3.90 m (12 ft. 10 in.)
F	Maximum Vertical Wall	6.48 m (21 ft. 3 in.)

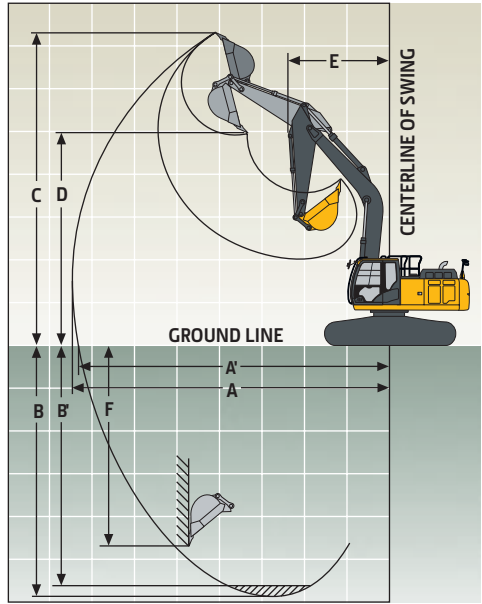

Machine Dimensions		300G LC	
Arm Length	3.11 m (10 ft. 2 in.)	3.76 m (12 ft. 4 in.)	
A Overall Length	10.66 m (35 ft. 0 in.)	10.71 m (35 ft. 2 in.)	
B Overall Height	3.20 m (10 ft. 6 in.)	3.38 m (11 ft. 1 in.)	
C Tail-Swing Radius	3.25 m (10 ft. 8 in.)		
D Distance Between Idler/Sprocket Centerline	4.05 m (13 ft. 3 in.)		
E Undercarriage Length	4.94 m (16 ft. 2 in.)		
F Counterweight Clearance	1.17 m (3 ft. 10 in.)		
G Upperstructure Width	2.99 m (9 ft. 10 in.)		
H Cab Height	3.11 m (10 ft. 2 in.)		
I Track Width with Triple Semi-Grouser Shoes	700 mm (28 in.) / 800 mm (32 in.)		
J Gauge Width	2.59 m (8 ft. 6 in.)		
K Ground Clearance	0.51 m (20 in.)		
L Overall Width with Triple Semi-Grouser Shoes			
700 mm (28 in.)	3.29 m (10 ft. 10 in.)		
800 mm (32 in.)	3.39 m (11 ft. 1 in.)		

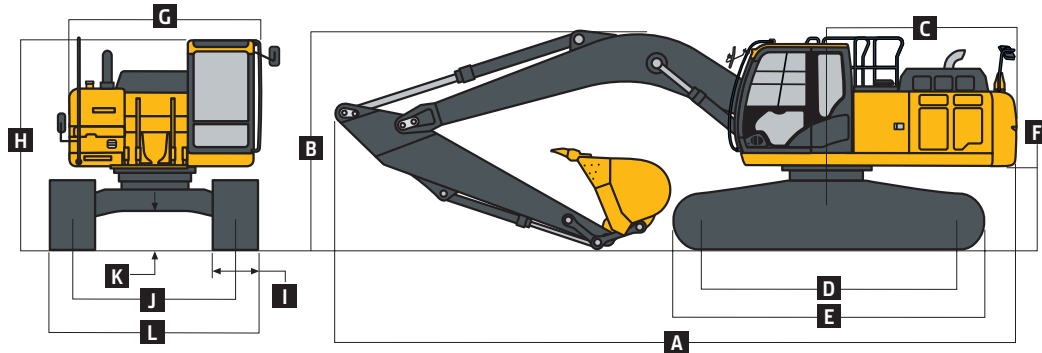

Lift Capacities

Boldface type indicates hydraulically limited capacity; lightface type indicates stability-limited capacities, in kg (lb.). Ratings at bucket lift hook; machine equipped with 957-kg (2,110 lb.) bucket; standard gauge; and situated on firm, uniform supporting surface. Total load includes weight of cables, hook, etc. Figures do not exceed 87 percent of hydraulic capacities or 75 percent of weight needed to tip machine. All lift capacities are based on ISO 10567.

LOAD POINT HEIGHT	HORIZONTAL DISTANCE FROM CENTERLINE OF ROTATION											
	1.5 m (5 ft.)		3.0 m (10 ft.)		4.5 m (15 ft.)		6.0 m (20 ft.)		7.5 m (25 ft.)		9.0 m (30 ft.)	
	Over Front	Over Side	Over Front	Over Side	Over Front	Over Side	Over Front	Over Side	Over Front	Over Side	Over Front	Over Side
<i>With 3.11-m (10 ft. 2 in.) arm and 700-mm (28 in.) shoes</i>												
6.0 m (20 ft.)							6300 (13,760)	6300 (13,760)	6130 (13,190)	5290 (11,340)		
4.5 m (15 ft.)					9000 (19,330)	9000 (19,330)	7370 (15,970)	7370 (15,970)	6570 (14,330)	5150 (11,070)		
3.0 m (10 ft.)					11 980 (25,720)	11 200 (24,150)	8770 (18,960)	7120 (15,350)	7270 (15,800)	4950 (10,650)	4730	3590
1.5 m (5 ft.)					14 400 (31,030)	10 460 (22,520)	10 090 (21,810)	6750 (14,530)	7980 (17,150)	4750 (10,220)	5570	3500
Ground Line					15 450 (33,420)	10 110 (21,740)	10 950 (23,690)	6500 (13,980)	7810 (16,800)	4610 (9,910)		
-1.5 m (-5 ft.)	5990 (13,420)	5990 (13,420)	9420 (21,410)	9420 (21,410)	15 380 (33,320)	10 030 (21,550)	11 090 (23,820)	6390 (13,750)	7740 (16,650)	4540 (9,770)		
-3.0 m (-10 ft.)	11 070 (24,860)	11 070 (24,860)	15 650 (35,600)	15 650 (35,600)	14 370 (31,100)	10 120 (21,740)	10 620 (22,910)	6420 (13,810)	7800	4590		
-4.5 m (-15 ft.)			16 830 (36,190)	16 830 (36,190)	12 110 (25,970)	10 370 (22,320)	8730 (18,420)	6610 (14,280)				
<i>With 3.11-m (10 ft. 2 in.) arm and 800-mm (32 in.) shoes</i>												
6.0 m (20 ft.)							6300 (13,760)	6300 (13,760)	6130 (13,190)	5360 (11,480)		
4.5 m (15 ft.)					9000 (19,330)	9000 (19,330)	7370 (15,970)	7370 (15,970)	6570 (14,330)	5220 (11,210)		
3.0 m (10 ft.)					11 980 (25,720)	11 330 (24,420)	8770 (18,960)	7210 (15,530)	7270 (15,800)	5020 (10,790)	4730	3640
1.5 m (5 ft.)					14 400 (31,030)	10 590 (22,800)	10 090 (21,810)	6830 (14,720)	7990 (17,330)	4820 (10,360)	5570	3550
Ground Line					15 450 (33,420)	10 240 (22,020)	10 950 (23,690)	6580 (14,170)	7910 (17,020)	4670 (10,050)		
-1.5 m (-5 ft.)	5990 (13,420)	5990 (13,420)	9420 (21,410)	9420 (21,410)	15 380 (33,320)	10 160 (21,830)	11 170 (24,120)	6470 (13,930)	7840 (16,860)	4600 (9,910)		
-3.0 m (-10 ft.)	11 070 (24,860)	11 070 (24,860)	15 650 (35,600)	15 650 (35,600)	14 370 (31,100)	10 240 (22,020)	10 620 (22,910)	6500 (14,000)	7900	4660		
-4.5 m (-15 ft.)			16 830 (36,190)	16 830 (36,190)	12 110 (25,970)	10 500 (22,590)	8730 (18,420)	6700 (14,470)				

Lift Capacities (continued) 300G LC

Boldface type indicates hydraulically limited capacity; lightface type indicates stability-limited capacities, in kg (lb.). Ratings at bucket lift hook; machine equipped with 957-kg (2,110 lb.) bucket; standard gauge; and situated on firm, uniform supporting surface. Total load includes weight of cables, hook, etc. Figures do not exceed 87 percent of hydraulic capacities or 75 percent of weight needed to tip machine. All lift capacities are based on ISO 10567.

HORIZONTAL DISTANCE FROM CENTERLINE OF ROTATION

LOAD POINT HEIGHT	1.5 m (5 ft.)		3.0 m (10 ft.)		4.5 m (15 ft.)		6.0 m (20 ft.)		7.5 m (25 ft.)		9.0 m (30 ft.)			
	Over Front	Over Side	Over Front	Over Side	Over Front	Over Side	Over Front	Over Side	Over Front	Over Side	Over Front	Over Side		
<i>With 3.76-m (12 ft. 4 in.) arm and 700-mm (28 in.) shoes</i>														
7.5 m (25 ft.)										4330	4330			
6.0 m (20 ft.)										5410	5400			
										(11,880)	(11,570)			
4.5 m (15 ft.)								6530	6530	5950	5230	4420	3720	
								(14,150)	(14,150)	(12,970)	(11,240)	(8,520)	(7,950)	
3.0 m (10 ft.)					10 590	10 590	8000	7260	6730	5010	5700	3620		
					(31,310)	(31,310)	(22,740)	(22,740)	(17,300)	(15,630)	(14,630)	(10,770)	(11,530)	(7,740)
1.5 m (5 ft.)					13 380	10 670	9470	6830	7560	4780	5920	3500		
					(28,820)	(22,980)	(20,480)	(14,710)	(16,390)	(10,280)	(12,710)	(7,500)		
Ground Line			5670	5670	15 000	10 160	10 570	6520	7810	4600	5820	3400		
			(13,000)	(13,000)	(32,430)	(21,850)	(22,870)	(14,020)	(16,790)	(9,880)	(12,500)	(7,300)		
-1.5 m (-5 ft.)	5650	5650	9100	9100	15 440	9970	11 050	6350	7690	4490	5050	3360		
	(12,640)	(12,640)	(20,640)	(20,640)	(33,440)	(21,420)	(23,730)	(13,650)	(16,530)	(9,650)				
-3.0 m (-10 ft.)	9450	9450	13 660	13 660	14 900	9970	10 890	6320	7680	4480				
	(21,200)	(21,200)	(31,010)	(31,010)	(32,250)	(21,440)	(23,530)	(13,590)	(16,520)	(9,640)				
-4.5 m (-15 ft.)	14 050	14 050	19 080	19 080	13 270	10 150	9720	6430						
	(31,670)	(31,670)	(41,110)	(41,110)	(28,560)	(21,840)	(20,810)	(13,860)						
-6.0 m (-20 ft.)			13 820	13 820	9700	9700								
					(20,230)	(20,230)								

With 3.76-m (12 ft. 4 in.) arm and 800-mm (32 in.) shoes

7.5 m (25 ft.)										4330	4330			
6.0 m (20 ft.)										5410	5410			
										(11,880)	(11,710)			
4.5 m (15 ft.)								6530	6530	5950	5300	4420	3770	
								(14,150)	(14,150)	(12,970)	(11,380)	(8,520)	(8,070)	
3.0 m (10 ft.)					10 590	10 590	8000	7340	6730	5080	5700	3670		
					(31,310)	(31,310)	(22,740)	(22,740)	(17,300)	(15,810)	(14,630)	(10,910)	(11,530)	(7,860)
1.5 m (5 ft.)					13 380	10 800	9470	6920	7560	4850	6000	3550		
					(28,820)	(23,250)	(20,480)	(14,890)	(16,390)	(10,420)	(12,890)	(7,610)		
Ground Line			5670	5670	15 000	10 290	10 570	6600	7910	4660	5900	3450		
			(13,000)	(13,000)	(32,430)	(22,130)	(22,870)	(14,210)	(17,010)	(10,020)	(12,670)	(7,410)		
-1.5 m (-5 ft.)	5650	5650	9100	9100	15 440	10 090	11 080	6430	7790	4550	5050	3410		
	(12,640)	(12,640)	(20,640)	(20,640)	(33,440)	(21,690)	(23,980)	(13,840)	(16,750)	(9,790)				
-3.0 m (-10 ft.)	9450	9450	13 660	13 660	14 900	10 100	10 890	6400	7780	4540				
	(21,200)	(21,200)	(31,010)	(31,010)	(32,250)	(21,710)	(23,530)	(13,780)	(16,740)	(9,780)				
-4.5 m (-15 ft.)	14 050	14 050	19 080	19 080	13 270	10 280	9720	6510						
	(31,670)	(31,670)	(41,110)	(41,110)	(28,560)	(22,110)	(20,810)	(14,040)						
-6.0 m (-20 ft.)			13 820	13 820	9700	9700								
					(20,230)	(20,230)								

Buckets

A full line of buckets is offered to meet a wide variety of applications. Digging forces are with power boost. Buckets are equipped with John Deere TK-Series Bucket Teeth standard. Replaceable cutting edges and a variety of teeth are available through John Deere Parts. Optional side cutters add 150 mm (6 in.) to bucket widths. Capacities are SAE heaped ratings.

Type Bucket	Bucket Width		Bucket Capacity		Bucket Weight		Bucket Dig Force		Arm Dig Force 3.11 m (10 ft. 2 in.)		Arm Dig Force 3.76 m (12 ft. 4 in.)		Bucket Tip Radius		Number of Teeth
	mm	in.	m ³	cu. yd.	kg	lb.	kN	lb.	kN	lb.	kN	lb.	mm	in.	
Heavy Duty	914	36	1.23	0.94	1010	2,226	189.7	42,653	144.1	32,397	125.1	28,126	1661	65.39	4
	1067	42	1.52	1.16	1147	2,530	189.7	42,653	144.1	32,397	125.1	28,126	1661	65.39	5
	1219	48	1.81	1.38	1213	2,675	189.7	42,653	144.1	32,397	125.1	28,126	1661	65.39	5
	1372	54	2.09	1.60	1328	2,928	189.7	42,653	144.1	32,397	125.1	28,126	1661	65.39	6

Bucket Selection Guide*

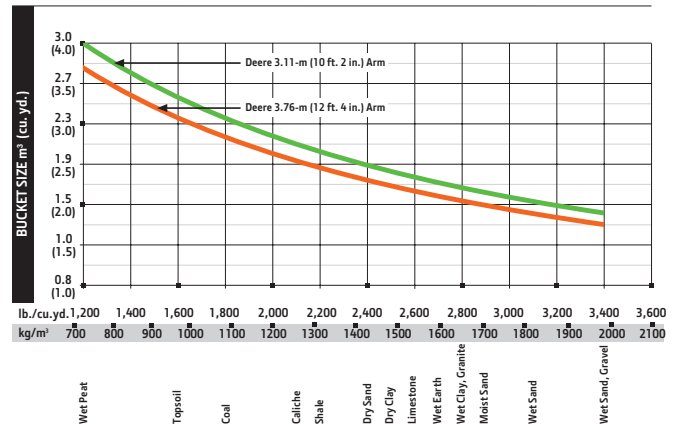

*Contact your John Deere dealer for optimum bucket and attachment selections. These recommendations are for general conditions and average use. Does not include optional equipment such as thumbs or couplers. Larger buckets may be possible when using light materials, for flat and level operations, less compacted materials, and volume loading applications such as mass-excavation applications in ideal conditions. Smaller buckets are recommended for adverse conditions such as off-level applications, rocks, and uneven surfaces. Bucket capacity indicated in SAE heaped.

Additional equipment

Key: ● Standard ▲ Optional or special

See your John Deere dealer for further information.

250G	300G	Engine
●	●	Auto-idle system
●	●	Automatic belt-tension device
●	●	Batteries (2 – 12 volt)
●	●	Coolant recovery tank
●	●	Dual-element dry-type air filter
●	●	Electronic engine control
●	●	Enclosed fan guard (conforms to SAE J1308)
●	●	Engine coolant to -37 deg. C (-34 deg. F)
●	●	Programmable auto shutdown
●	●	Fuel filter with water separator
●	●	Full-flow oil filter
●	●	Turbocharger with charge air cooler
●	●	Cool-on-demand hydraulic-driven fan
●	●	Glow-plug start aid
●	●	500-hour engine-oil-change interval
●	●	70% (35 deg.) off-level capability
●	●	Engine-oil-sampling valve
▲	▲	Hydraulic fan reverser
▲	▲	Chrome exhaust stack
▲	▲	Engine coolant heater
▲	▲	Severe-duty fuel filter
Hydraulic System		
●	●	Reduced-drift valve for boom down, arm in
●	●	Auxiliary hydraulic valve section
●	●	Spring-applied, hydraulically released automatic swing brake
●	●	Auxiliary hydraulic-flow adjustments through monitor
●	●	Auto power lift
●	●	5,000-hour hydraulic-oil-change interval
●	●	Hydraulic-oil-sampling valve
▲	▲	Auxiliary hydraulic lines
▲	▲	Auxiliary pilot and electric controls
▲	▲	Hydraulic filter restriction indicator kit
▲	▲	Load-lowering control / Anti-drift device
▲	▲	Single-pedal propel control
▲	▲	Control pattern change valve
Undercarriage		
●	●	Planetary drive with axial piston motors
●	●	Propel motor shields
●	●	Spring-applied, hydraulically released automatic propel brake
●	●	Track guides, front idler and center
●	●	2-speed propel with automatic shift
●	●	Upper carrier rollers (2)
●	●	Sealed and lubricated track chain
▲	▲	Triple semi-grouser shoes, 600 mm (24 in.)

250G	300G	Undercarriage (continued)
▲	▲	Triple semi-grouser shoes, 700 mm (28 in.)
▲	▲	Triple semi-grouser shoes, 800 mm (32 in.)
Upperstructure		
●	●	Right-hand, left-hand, and counter-weight mirrors
●	●	Vandal locks with ignition key: Cab door / Service doors / Toolbox
●	●	Debris screen in side panel
●	●	Remote-mounted engine oil and fuel filters
▲	▲	"D" channel guard
Front Attachments		
●	●	Centralized lubrication system
●	●	Dirt seals on all bucket pins
●	●	Less boom and arm
●	●	Oil-impregnated bushings
●	●	Reinforced resin thrust plates
●	●	Tungsten carbide thermal coating on arm-to-bucket joint
▲		Arm, 2.50 m (8 ft. 2 in.)
▲		Arm, 2.96 m (9 ft. 9 in.)
	▲	Arm, 3.11 m (10 ft. 2 in.)
▲		Arm, 3.61 m (11 ft. 10 in.)
	▲	Arm, 3.76 m (12 ft. 4 in.)
▲	▲	Attachment quick-couplers
▲	▲	Boom cylinder with plumbing to main-frame for less boom and arm
▲	▲	Buckets: Heavy duty / Heavy-duty high capacity / Side cutters and teeth
▲	▲	Material clamps
▲	▲	Super-long fronts
Operator's Station		
●	●	Adjustable independent-control positions (levers-to-seat, seat-to-pedals)
●	●	AM/FM radio
●	●	Auto climate control/air conditioner/heater/pressurizer
●	●	Built-in Operator's Manual storage compartment and manual
●	●	Cell-phone power outlet, 12 volt, 60 watt, 5 amp
●	●	Coat hook
●	●	Deluxe suspension cloth seat with 100-mm (4 in.) adjustable armrests
●	●	Floor mat
●	●	Front windshield wiper with intermittent speeds
●	●	Gauges (illuminated): Diesel Exhaust Fluid (DEF) / Engine coolant / Fuel
●	●	Horn, electric
●	●	Hourmeter, electric
●	●	Hydraulic shutoff lever, all controls
●	●	Hydraulic warm-up control

250G	300G	Operator's Station (continued)
●	●	Interior light
●	●	Large cup holder
●	●	Machine Information Center (MIC)
●	●	Mode selectors (illuminated): Power modes – 3 / Travel modes – 2 with automatic shift / Work mode – one
●	●	Multifunction, color LCD monitor with: Diagnostic capability / Multiple-language capabilities / Maintenance tracking / Clock / System monitoring with alarm features: Auto-idle indicator, engine air cleaner restriction indicator light, engine check, engine coolant temperature indicator light with audible alarm, engine oil pressure indicator light with audible alarm, low-alternator-charge indicator light, low-fuel indicator light, low DEF indication with audible alarm, fault code alert indicator, fuel-rate display, wiper-mode indicator, work-lights-on indicator, and work-mode indicator
●	●	Motion alarm with cancel switch (conforms to SAE J994)
●	●	Power-boost switch on right console lever
●	●	Auxiliary hydraulic control switches in right console lever
●	●	SAE 2-lever control pattern
●	●	Seat belt, 51 mm (2 in.), retractable
●	●	Tinted glass
●	●	Transparent tinted overhead hatch
●	●	Hot/cold beverage compartment
▲	▲	Air-suspension heated seat
▲	▲	Hydraulic oil filter restriction indicator light
▲	▲	Protection screens for cab front, rear, and side
▲	▲	Seat belt, 76 mm (3 in.), non-retractable
▲	▲	Window vandal-protection covers
Electrical		
●	●	100-amp alternator
●	●	Blade-type multi-fused circuits
●	●	Positive-terminal battery covers
●	●	Battery-disconnect switch
●	●	JDLINK™ Ultimate wireless communication system (available in specific countries; see your dealer for details)
▲	▲	Rearview camera
▲	▲	Cab extension wiring harness
Lights		
●	●	Work lights: Halogen / One mounted on boom / One mounted on frame
▲	▲	2 lights mounted on cab / One mounted on right side of boom / One mounted under engine hood

Net engine power is with standard equipment including air cleaner, exhaust system, alternator, and cooling fan, at test conditions specified per ISO 9249. No derating is required up to 3050-m (10,000 ft.) altitude. Specifications and design subject to change without notice. Wherever applicable, specifications are in accordance with SAE standards. Except where otherwise noted, these specifications are based on units with 800-mm (32 in.) triple semi-grouser shoes, full fuel tanks, and 79-kg (175 lb.) operators; a 250G LC unit with 1219-mm (48 in.) bucket and 5112-kg (11,270 lb.) counterweight; and a 300G LC unit with 1067-mm (42 in.) bucket and 5600-kg (12,346 lb.) counterweight.

