

# CENTER-CONTROLLED RIDER PALLET JACK

 **TOYOTA**  
**INDUSTRIAL EQUIPMENT**  
REACH NEW HEIGHTS

## LONG DISTANCE **RIDER**

- ▶ 6000 - 8000 lb. Capacity
- ▶ Regenerative Braking
- ▶ Electronic Coast Control Option
- ▶ Up to 103 in. Fork Option
- ▶ Cold Conditioning Package Option



8HBC30-40

CLASS  
**3**

ELECTRIC PALLET JACKS/STACKERS/TOW TRACTORS

[ToyotaForklift.com](http://ToyotaForklift.com)

# MASTER OF THE GROUND GAME

**THE TOYOTA CENTER-CONTROLLED RIDER.** Just get in and go. With easy maneuverability and a comfortable mid-truck operator compartment, the Center-Controlled Rider makes cross-warehouse hauling fast and efficient. It doubles as a low-level order picker, too. Giving you complete command of your ground game and a healthy boost in productivity, shift after shift.

## CENTER-CONTROLLED RIDER ADVANTAGES

- ▶ **MULTIFUNCTION CONTROL HANDLE** with ergonomically positioned handgrips; dual thumbwheels; and lift, lower and horn buttons for simplified operation of all controls with either hand
- ▶ **HIGH-SPEED INTERLOCK** to maintain top travel speed for long-distance transport without continuously pressing a button
- ▶ **PROGRAMMABLE PERFORMANCE PARAMETERS** customizable through a digital display to adjust for a variety of job applications and operator skill levels
- ▶ **BOX RAIL FORK CONSTRUCTION** provides torsional rigidity and maximum strength to prevent premature fatigue
- ▶ **SOLID STEEL PULL RODS** add strength throughout the entire length of forks, and are much less likely to bend or flex than push rods, resulting in less maintenance



▶ **DUAL LIFT CYLINDERS** provide efficient hydraulic power for smooth, effortless lifting to reduce component wear

---

▶ **SELF-DIAGNOSTICS** simplify troubleshooting and eliminate the need for an external hand-held analyzer

---

UP TO **103** IN.  
FORK OPTION

---

▶ **GLANCE & GO DISPLAY** provides a quick summary of key information

---

▶ **CUSHIONED STABILITY HANDRAIL** offers convenient control during high-speed travel

---

▶ **ELECTRONIC COAST CONTROL OPTION** augments productivity by eliminating the need for operator to climb on and off during floor-level order picking

---



# CENTER-CONTROLLED RIDER PALLET JACK

CAPACITY  
**6000 - 8000 LBS.**

FORK SIZE  
**36 - 103 IN.**

OVERALL FORK WIDTH  
**22 - 27.5 IN.**

## INDUSTRIES



## STANDARD FEATURES

### PERFORMANCE

- AC drive motor with thermal protection & current limiting
- 24-Volt electrical system
- 6" lift
- Programmable performance
  - Adjustable maximum speed
  - Adjustable acceleration
- Fault code memory with hour meter reading
- Regenerative braking
- On/off key switch
- Lift limit switch
- Multiple hour meter indicator
- Battery discharge indicator with lift interrupt
- Fused control & power circuits
- Hydraulic overload protection valve
- Dual 1.25"-dia. lift cylinders
- Polyurethane torsion block stabilizing casters<sup>1</sup>
- Heavy-duty spring-loaded stabilizing casters<sup>2</sup>

### BODY/EXTERIOR DESIGN

- 31.5"-long x 13.44"-wide battery compartment<sup>3</sup>
- SB-175 battery connector (gray)
- Cold storage conditioning

### ERGONOMICS

- Multifunction control handle with ergonomically angled handgrips & wrap-around hand guard
- Dual thumbwheels with twist grips for directional control & travel speed
- Intuitively positioned lift/lower buttons
- Adjustable height control handle (3-position); dual hand brake levers
- Low-effort control handle
- High-speed interlock button
- Bubble-cushioned operator floor mat, padded backrest & knee pad
- Walk-through operator compartment
- Low platform step height

### DURABILITY

- Control Area Network (CAN-bus) communications
- Welded construction with reinforced heavy-duty bumper
- Powder coat paint finish
- Box rail fork construction
- Steel bulkhead wrappers
- Forged rectangular steel tension rods
- Heavy-duty bushings & pins
- Solid trail fork casting
- Tapered fork tips with pallet entry slides
- Four-point lift linkage
- High-strength polymer service cover
- Rubber drive tire
- Hall-effect switches
- 48" load backrest extension

### SERVICEABILITY

- AC drive motor (no brushes or commutator)
- Self-adjusting electric disc brake
- One-piece, lightweight service access cover
- Error indicator with self-diagnostics
- Teflon<sup>®</sup>-coated PolyLube™ lift linkage bushings (maintenance free)

### SAFETY

- Wrap-around hand guard
- Control handle with dual brake levers
- Electronic horn

<sup>1</sup> Standard only with fork lengths below 84" (2134 mm).

<sup>2</sup> Standard only with fork lengths 84" (2134 mm) & above.

<sup>3</sup> Battery compartment length is 30.25" (768 mm) when equipped with optional battery compartment rollers.

## OPTIONAL EQUIPMENT

- 48," 60" and 72" load backrest extension
- Electronic travel alarm (forward & reverse)
- Controller splash guard<sup>1</sup>
- Keyless on/off switch<sup>2</sup>
- Power hookup for onboard terminal (24-Volt, 2 amp)<sup>3</sup>
- Power hookup for onboard terminal (24-Volt, 10 amp)<sup>3</sup>
- Storage tray with clipboard, battery compartment mounted<sup>8</sup>
- Pallet entry/exit rollers (single length pallet forks only 36"- 60")
- Steel bumper skirt (2.25" underclearance)<sup>7</sup>
- Turtle speed (3-position key switch)
- Jog buttons with turtle speed
- (3-position key switch)
- Dual stretch wrap holder, load backrest mounted
- Lubrication package for pivot points (grease fittings)
- Steering bearing, greaseable<sup>9</sup>
- 6" extended operator compartment
- Battery compartment rollers with dual side gates<sup>4</sup>
- Battery side gate interlock switches<sup>5</sup>
- 32"-high battery retaining wall<sup>6</sup>
- Battery spacer kit
- Polyurethane drive tire
- Non-marking rubber drive tire
- Heavy-duty load wheels (Vulkollan®)<sup>10</sup>
- Heavy-duty spring-loaded stabilizing casters
- Load wheel debris diversion device<sup>13</sup>
- Polyurethane load wheels (tan durometer 95)<sup>10</sup>
- Load wheels, single axle/dual<sup>10</sup>
- Load wheels, single axle/triple<sup>10</sup>
- Power steering<sup>16</sup>
- Cold storage conditioning<sup>14-15</sup>
- Special paint color, complete truck
- UL-approved model type "E"<sup>11</sup>
- UL-approved model type "EE"<sup>12</sup>
- Factory pre-programmed maximum travel speed of 5 mph<sup>16</sup>

1 Not available with option code #8087.

2 Not available with option code #8100.

3 Not available with option codes #8086 or 8087.

4 Roller height is 8.1" (206 mm).

5 Requires option code #8018.

6 Standard Battery Retaining Wall Height is 25" (635 mm).

7 Not available with option codes #8108 or 100609. This option includes Heavy-Duty Spring-Loaded Stabilizing Casters.

8 Not available with option code #8104.

9 Required when ordering cold storage.

10 Not available in combination with any other load wheel option. Option code #8201 uses sealed-type bearings. Option code #8200 uses grease fittings on axles.

11 Not available with option codes #8102 or 8103.

12 Not available with option codes #8102, 8103, 8022, 8069, 8098, 8122 or 8123.

13 Requires ordering option code #110010. Not available with option code #8087.

14 Contact your local dealer for more information on environmental conditioning.

15 Not available with option codes #8086, 8087, 8067 or 8093. Due to changed steering geometry, option code #8120 should be considered for some operators.

16 Not available with option codes #8121 or 8069.



# CENTER-CONTROLLED RIDER PALLET JACK

## TRUCK SPECIFICATIONS

GENERAL DATA			MODEL NUMBER							
GENERAL DATA			8HBC30							
Load Capacity	lb (kg)		6000 (2725)							
Power Type			Battery							
Operator Position			Center-Controlled Rider							
Tire Type	Drive / Caster / Load		Rubber / Polyurethane / Polyurethane							
Wheels (x = driven)	Front / Rear		1 Drive, 2 Heavy-Duty Casters / 2 Load							
EXTERIOR DIMENSIONS			8HBC30							
<b>A</b> Fork Width	in (mm)		9 (229)				10 (254)			
<b>B</b> Overall Fork Width	in (mm)		22 (559) or 24 (610) or 27 (686)				22.625 (575) or 24.5 (622) or 27.5 (699)			
<b>C</b> Fork Height	Lowered	in (mm)	3.25 (83)							
	Raised	in (mm)	9.25 (235)							
<b>E</b> Fork Lift	in (mm)		6 (152)							
<b>F</b> Fork Length	in (mm)		36 (914) <sup>1,5</sup>	42 (1067) <sup>1,5</sup>	48 (1220) <sup>1,5</sup>	60 (1524) <sup>1,5</sup>	84 (2134) <sup>1,2,6</sup>	93 (2362) <sup>1,2,6</sup>	96 (2438) <sup>1,2,6</sup>	103 (2616) <sup>1,2,3,6</sup>
<b>G</b> Overall Width	in (mm)		32.5 (826)							
<b>H</b> Overall Length	in (mm)		90.3 (2294)	96.3 (2446)	102.3 (2598)	114.3 (2903)	138.75 (3524)	145.50 (3721)	148.75 (3778)	155.75 (3956)
	<b>I</b> Wheelbase	Lowered	in (mm)	72.8 (1849)	78.8 (2002)	84.8 (2154)	96.8 (2459)	105.2 (2672)	105.2 (2672)	105.2 (2672)
Raised		in (mm)	68.1 (1730)	74.1 (1882)	80.1 (2035)	92.1 (2339)	100.55 (2553)	100.55 (2553)	100.55 (2553)	107.5 (2731)
<b>J</b> Turning Radius	in (mm)		74.7 (1897)	80.6 (2047)	86.5 (2197)	98.3 (2497)	106.6 (2708)	106.6 (2708)	106.6 (2708)	113.5 (2883)
Gross Weight Without Battery	lb (kg)		1280 (581)	1300 (590)	1320 (599)	1370 (621)	1730 (785)	1770 (803)	1780 (807)	1805 (819)
<b>L</b> Head Length	in (mm)		54.6 (1387)							
<b>M</b> Power Unit Height	in (mm)		31.40 (798)							
<b>N</b> Overall Height (handle)	Position 1	in (mm)	56.0 (1422)							
	Position 2	in (mm)	53.0 (1346)							
	Position 3	in (mm)	49.8 (1265)							
<b>Q</b> Operator's Platform Height	Lowered	in (mm)	4 (102)							
	Raised	in (mm)	10 (254)							
<b>R</b> Operator's Platform Depth	in (mm)		17.25 (438)							
<b>S</b> Distance from Bumper to Center of Drive Tire	in (mm)		9.9 (251)							
<b>T</b> Bumper Underclearance	in (mm)		4.75 (121)							
<b>U</b> Bumper Height	in (mm)		9.75 (248)							
PERFORMANCE DATA			8HBC30							
Speeds	Full Load	mph (km/h)	6.2 (10.0)							
	No Load	mph (km/h)	8.8 (14.2)							
Gradeability	Full Load	%	10							
	No Load	%	10							
TIRES			8HBC30							
Tires	Number	Front / Rear	3 / 2							
	Size (dia. x width)	Drive (front)	in (mm)	12 x 4.75 (305 x 121)						
		Caster (front)	in (mm)	4 x 2.5 (102 x 64)						
		Load (rear)	in (mm)	3.25 x 5.91 (83 x 150)						
POWER SYSTEM			8HBC30							
Battery	Amps Max	V / Ah	750							
	Voltage	V / Ah	24							
	Connector / Color		SB-175 (gray)							
	Connector Cable Location		B							
	Connector Cable Length	in (mm)	18 (457)							
	Compartment Length	in (mm)	31.5 (800) <sup>4</sup>							
Battery Weight	Width	in (mm)	13.44 (341)							
	Maximum	lb (kg)	1500 (680)							
	Minimum	lb (kg)	490 (222)							
Electric Motors	Drive (60 minutes)	hp (kW)	5.5 (4.1)							

1 48" (1219 mm) load backrest extension is standard.  
 2 Forks are designed to handle two 48" (1219 mm) long pallets.  
 3 These forks have a 7" (178 mm) longer wheelbase to allow for load overhang & proper load wheel drop.  
 4 Length = 30.25" (768 mm) when equipped with optional Battery Compartment Rollers.  
 5 Polyurethane Torsion Block Stabilizing Casters are standard.  
 6 Heavy-Duty Spring-Loaded Stabilizing Casters are standard.

# TRUCK SPECIFICATIONS

## MODEL NUMBER

GENERAL DATA			8HBC40			
Load Capacity	lb (kg)		8000 (3632)			
Power Type			Battery			
Operator Position			Center-Controlled Rider			
Tire Type	Drive / Caster / Load		Rubber / Polyurethane / Polyurethane			
Wheels (x = driven)	Front / Rear		1 Drive, 2 Heavy-Duty Casters / 2 Load			
EXTERIOR DIMENSIONS			8HBC40			
<b>A</b>	Fork Width	in (mm)	10 (254)			
<b>B</b>	Overall Fork Width	in (mm)	27.5 (699)			
<b>C</b>	Fork Height	Lowered	3.25 (83)			
		Raised	9.25 (235)			
<b>E</b>	Fork Lift	in (mm)	6 (152)			
<b>F</b>	Fork Length	in (mm)	84 (2134) <sup>1,2,5</sup>	93 (2362) <sup>1,2,5</sup>	96 (2438) <sup>1,2,5</sup>	103 (2616) <sup>1,2,3,5</sup>
<b>G</b>	Overall Width	in (mm)	32.5 (826)			
<b>H</b>	Overall Length	in (mm)	138.75 (3524)	146.50 (3721)	148.75 (3778)	155.75 (3956)
<b>I</b>	Wheelbase	Lowered	105.2 (2672)			
		Raised	100.5 (2553)			
<b>J</b>		in (mm)	100.5 (2553)	100.5 (2553)	100.5 (2553)	107.5 (2731)
<b>K</b>	Turning Radius	in (mm)	106.6 (2708)	106.6 (2708)	106.6 (2708)	113.5 (2883)
	Gross Weight Without Battery	lb (kg)	1940 (880)	1980 (898)	1990 (903)	2015 (914)
<b>L</b>	Head Length	in (mm)	54.6 (1387)			
<b>M</b>	Power Unit Height	in (mm)	31.40 (798)			
<b>N</b>		in (mm)	56.0 (1422)			
<b>O</b>	Overall Height (handle)	Position 1	56.0 (1422)			
		Position 2	53.0 (1346)			
<b>P</b>		in (mm)	49.8 (1265)			
<b>Q</b>	Operator's Platform Height	Lowered	4.0 (102)			
		Raised	11.5 (292)			
<b>R</b>	Operator's Platform Depth	in (mm)	17.25 (438)			
<b>S</b>	Distance from Bumper to Center of Drive Tire	in (mm)	9.9 (251)			
<b>T</b>	Bumper Underclearance	in (mm)	4.75 (121)			
<b>U</b>	Bumper Height	in (mm)	9.75 (248)			
PERFORMANCE DATA			8HBC40			
Speeds	Full Load	mph (km/h)	6.2 (10.0)			
	No Load	mph (km/h)	8.8 (14.2)			
Gradeability	Full Load	%	8			
	No Load	%	10			
TIRES			8HBC40			
	Number	Front / Rear	3 / 2			
Tires	Size (dia. x width)	Drive (front)	12 x 4.75 (305 x 121)			
		Caster (front)	4 x 2.5 (102 x 64)			
		Load (rear)	3.25 x 5.91 (83 x 150)			
POWER SYSTEM			8HBC40			
	Amps Max	V / Ah	750			
	Voltage	V / Ah	24			
Battery	Connector / Color		SB-175 (gray)			
	Connector Cable Location		B			
	Connector Cable Length	in (mm)	18 (457)			
	Compartment Length	in (mm)	31.5 (800) <sup>4</sup>			
Battery Weight	Width	in (mm)	13.44 (341)			
	Maximum	lb (kg)	1500 (680)			
	Minimum	lb (kg)	490 (222)			
Electric Motors	Drive (60 minutes)	hp (kW)	5.5 (4.1)			

1 48" (1219 mm) load backrest extension is standard.  
2 Forks are designed to handle two 48" (1219 mm) long pallets.  
3 These forks have a 7" (178 mm) longer wheelbase to allow for load overhang & proper load wheel drop.  
4 Length = 30.25" (768 mm) when equipped with optional Battery Compartment Rollers.  
5 Heavy-Duty Spring-Loaded Stabilizing Casters are standard.

EXTERIOR DIMENSIONS

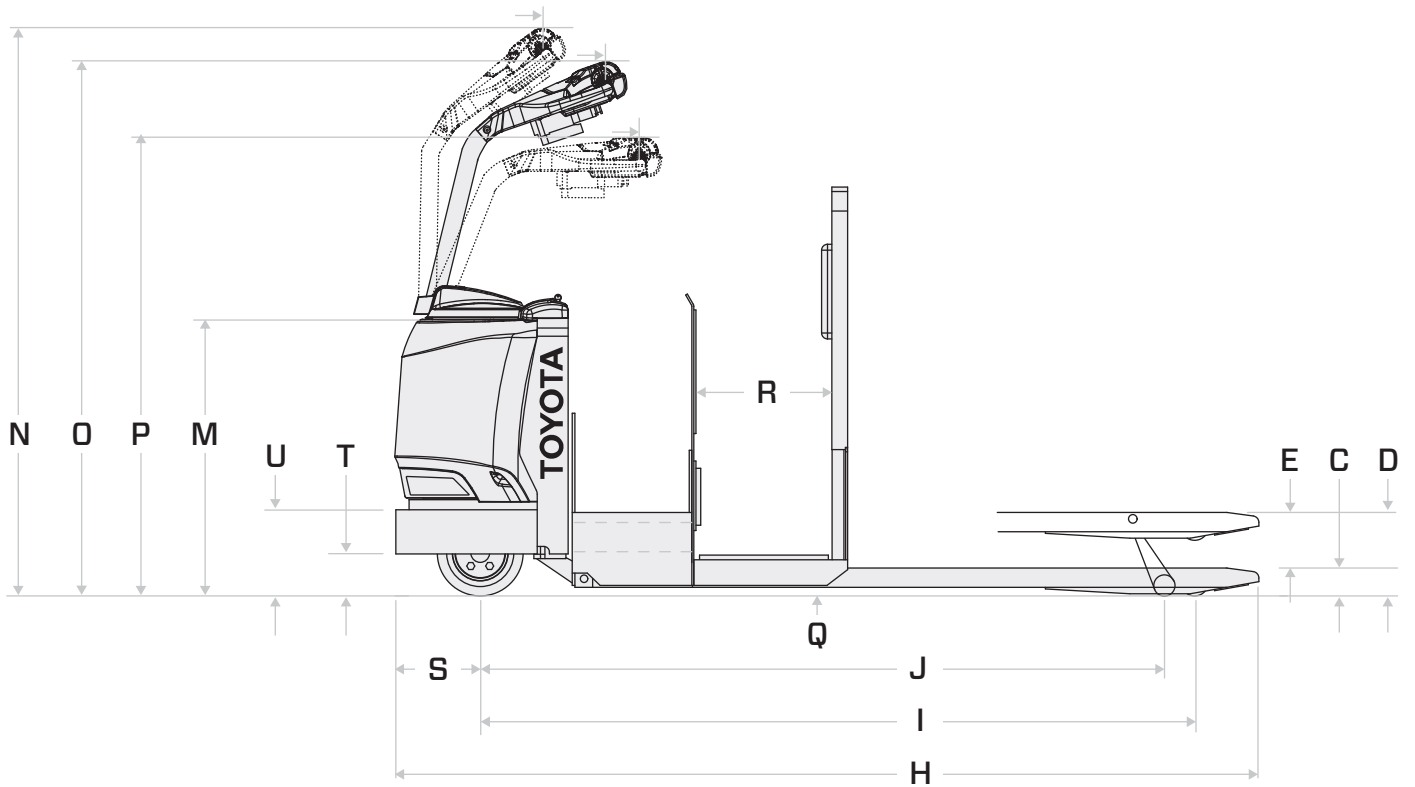
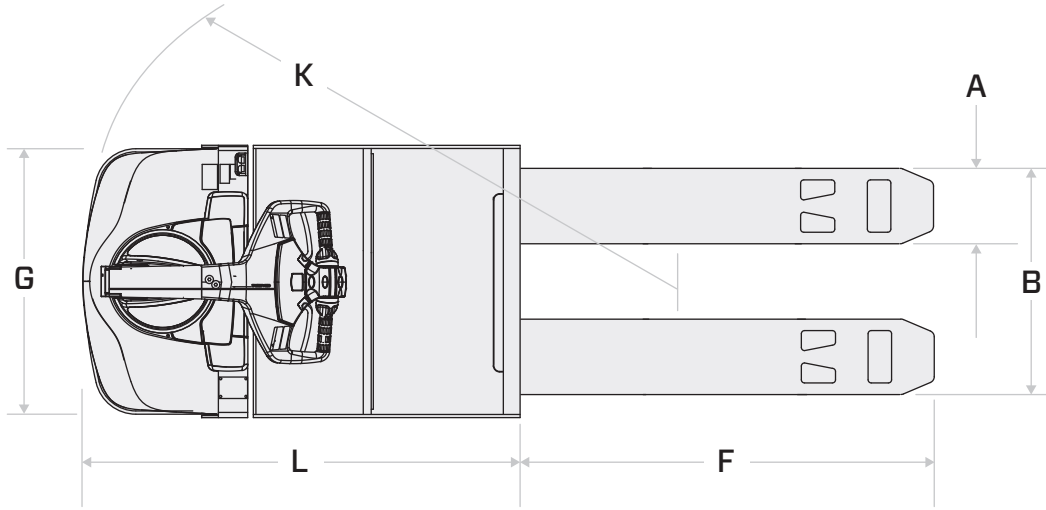



## RIGHT-ANGLE STACKING AISLE REQUIREMENTS

FORK LENGTH	PALLET LENGTH	PALLET WIDTH						
		30 (762)	32 (813)	36 (914)	40 (1016)	42 (1067)	44 (1118)	48 (1220)
in (mm)	in (mm)	in (mm)	in (mm)	in (mm)	in (mm)	in (mm)	in (mm)	in (mm)
<b>8HBC30</b>								
36 (914) <sup>1</sup>	36 (914)	79.8 (2027)	79.8 (2027)	79.8 (2027)	79.8 (2027)	79.8 (2027)	79.8 (2027)	79.8 (2027)
42 (1067) <sup>1</sup>	42 (1067)	85.8 (2179)	85.8 (2179)	85.8 (2179)	85.8 (2179)	85.8 (2179)	85.8 (2179)	85.8 (2179)
48 (1220) <sup>1</sup>	48 (1220)	98.8 (2510)	98.8 (2510)	98.8 (2510)	98.8 (2510)	98.8 (2510)	98.8 (2510)	98.8 (2510)
60 (1524) <sup>1</sup>	60 (1524)	110.8 (2814)	110.8 (2814)	110.8 (2814)	110.8 (2814)	110.8 (2814)	110.8 (2814)	110.8 (2814)
84 (2134) <sup>2,7</sup>	2 x 48 (2 x 1220)	142.8 (3627)	142.6 (3622)	142.3 (3614)	142.0 (3607)	141.8 (3602)	141.6 (3597)	141.3 (3589)
93 (2362) <sup>3,7</sup>	2 x 48 (2 x 1220)	152.5 (3874)	152.4 (3871)	152.2 (3866)	151.9 (3858)	151.8 (3856)	151.7 (3853)	151.4 (3846)
96 (2438) <sup>4,7</sup>	2 x 48 (2 x 1220)	155.7 (3955)	155.6 (3952)	155.4 (3947)	155.1 (3940)	155.0 (3937)	154.9 (3934)	154.7 (3929)
103 (2616) <sup>5,7</sup>	2 x 48 (2 x 1220)	155.7 (3955)	155.6 (3952)	155.4 (3947)	155.1 (3940)	155.0 (3937)	154.9 (3934)	154.7 (3929)

FORK LENGTH	PALLET LENGTH	PALLET WIDTH						
		30 (762)	32 (813)	36 (914)	40 (1016)	42 (1067)	44 (1118)	48 (1220)
in (mm)	in (mm)	in (mm)	in (mm)	in (mm)	in (mm)	in (mm)	in (mm)	in (mm)
<b>8HBC40</b>								
84 (2134) <sup>2,7</sup>	2 x 48 (2 x 1220)	142.8 (3627)	142.6 (3622)	142.3 (3614)	142.0 (3607)	141.8 (3602)	141.6 (3597)	141.3 (3589)
93 (2362) <sup>3,7</sup>	2 x 48 (2 x 1220)	152.5 (3874)	152.4 (3871)	152.2 (3866)	151.9 (3858)	151.8 (3856)	151.7 (3853)	151.4 (3846)
96 (2438) <sup>4,7</sup>	2 x 48 (2 x 1220)	155.7 (3955)	155.6 (3952)	155.4 (3947)	155.1 (3940)	155.0 (3937)	154.9 (3934)	154.7 (3929)
103 (2616) <sup>5,7</sup>	2 x 48 (2 x 1220)	155.7 (3955)	155.6 (3952)	155.4 (3947)	155.1 (3940)	155.0 (3937)	154.9 (3934)	154.7 (3929)

**Minimum Aisle Width for Right-Angle Stacking**  
 Includes 4" (102 mm) clearance on each side of load.  
 Add a minimum of 12" (305 mm) for easy maneuvering.

1 Polyurethane Torsion Block Stabilizing Casters are standard.  
 2 For two 48" x 40" pallets entered on the 40" face, with a total of 12" of pallet overhanging the forks.  
 3 For two 48" x 40" pallets entered on the 40" face, with a total of 3" of pallet overhanging the forks.  
 4 For two 48" x 40" pallets entered on the 40" face.  
 5 For two 48" x 40" pallets entered on the 40" face, with a total of 7" of load overhang.  
 6 These forks have a 7" longer wheelbase to allow for load overhang & proper load wheel drop.  
 7 Heavy-Duty Spring-Loaded Casters are standard.



F2

F2

TOYOTA





## COUNT ON THE LEADER

- ▶ Toyota leads in quality, durability, reliability and value, thanks to advanced technology and the world-renowned Toyota Production System.
- ▶ With the broadest and most complete set of material-handling solutions in the industry, Toyota Dealers specialize in meeting all of your needs — from a single forklift to an entire fleet.
- ▶ Toyota's industry-leading network of dealers backs every forklift with proven product support. Resources include factory-trained service technicians, Toyota Genuine Parts, and flexible leasing and financing packages through Toyota Commercial Finance.

- ▶ Toyota forklifts have ranked No. 1 in safety and quality since 2002, according to studies conducted by Peerless Research Group.

For more information, including full specs, see your Toyota Dealer or [ToyotaForklift.com](http://ToyotaForklift.com).



Some product features described herein are optional. Please consult your dealer for specifications. Details of specifications and equipment are based on information available at time of printing and may change without notice.